



Trend's 3G Guide

Pocket Guide for UMTS testing

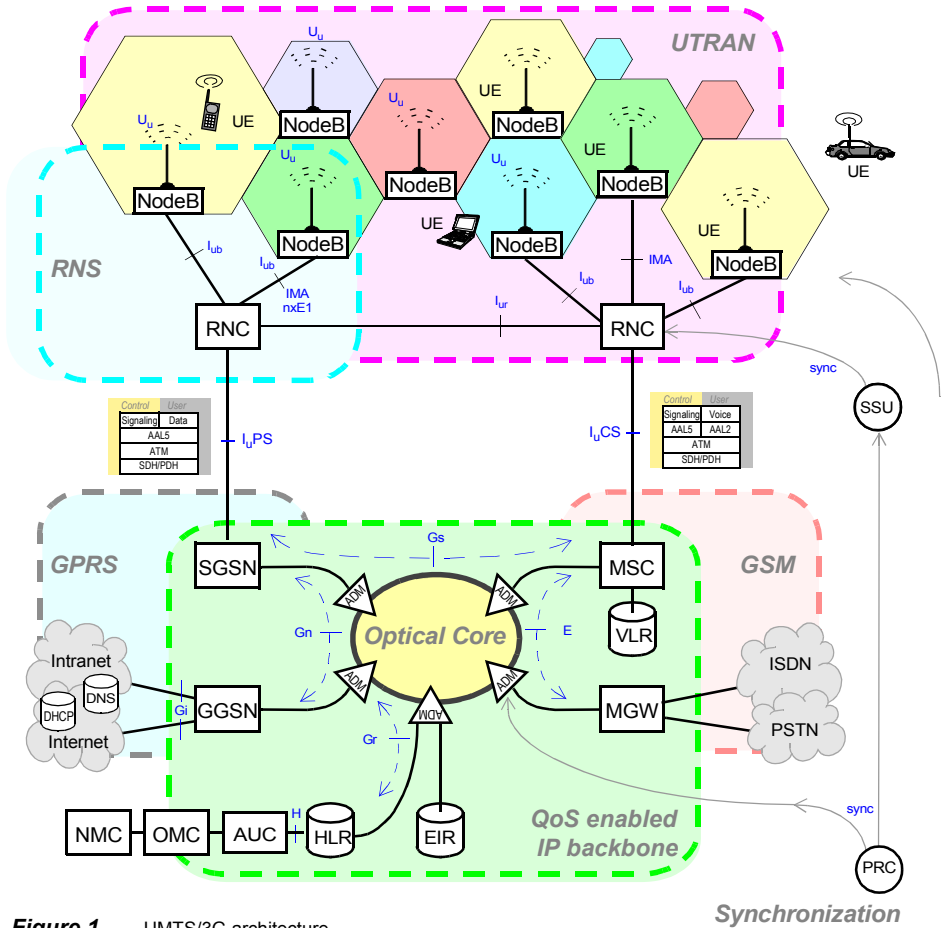

Figure 1 UMTS/3G architecture

Synchronization



AuroraForte

A powerful tool for testing the Physical, ATM and IP layer operation of ATM circuits. Provides IMA, E1, E3, DS1, DS3, ATM-25, STM-1/OC-3 and STM-4/OC-12 interfaces for unparallelled multi-circuit testing in ATM, xDSL and 3G networks. Physical and ATM BER testing. Advanced features, AAL5, OAM, QoS, SVC support and IP Ping over ATM, protocol decoding and remote testing, analysis of IP traffic composition.



VictoriaSDH/ATM/IP

Family of testers that combine IP, ATM and SDH capabilities up to 2.5 Gbit/s. Transmission functions include TCM, APS, M/N alarms, G.783 sequences, frequency deviation and $n \times 64$ and $n \times 56$ kbit/s tests at E1 and DS1 levels. ATM features include generation and analysis of ATM flows, QoS, OAM flows, AAL1/2/5 generation/analysis. Analysis of IP traffic composition also included.



VictoriaJitter/Wander

A cost-effective solution that provides complete loop fault management for control centres that support a large number of xDSL installations. Its remote testing capacities include: emulation of equipment at both central offices and customer premises, TDR, DMM, an extensive range of analogue measurements, spectrum analysis, ATM, PPP, IP and higher-layer protocol test.

User Circuit-Switched Voice Services

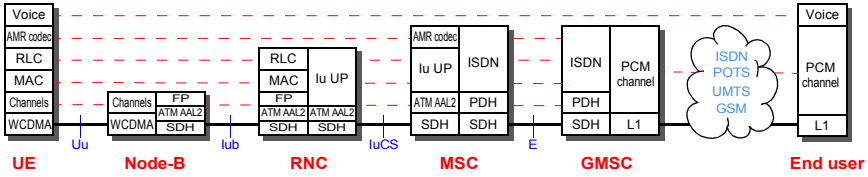

User Packet-Switched Data Services

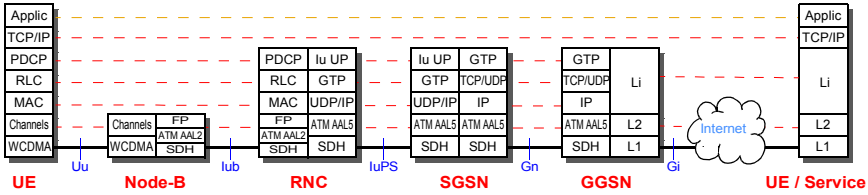

UMTS Control Plane

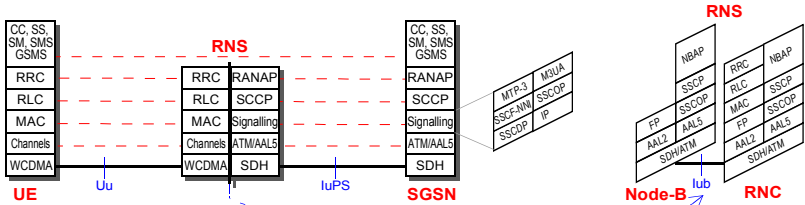

Figure 2 UMTS planes, protocols and interfaces

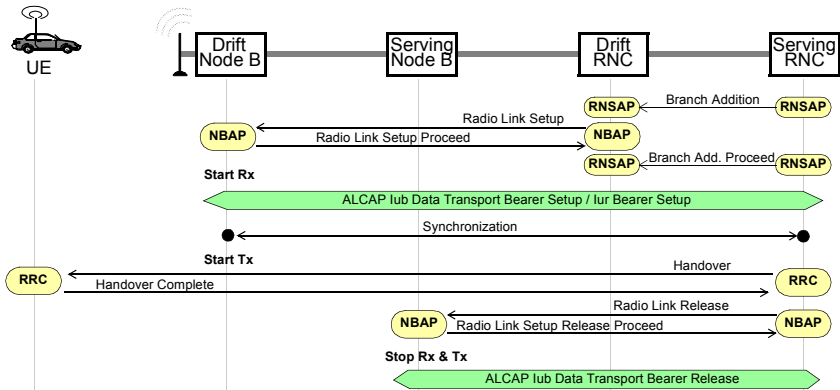

Figure 3 UTRAN signaling sample: soft handover

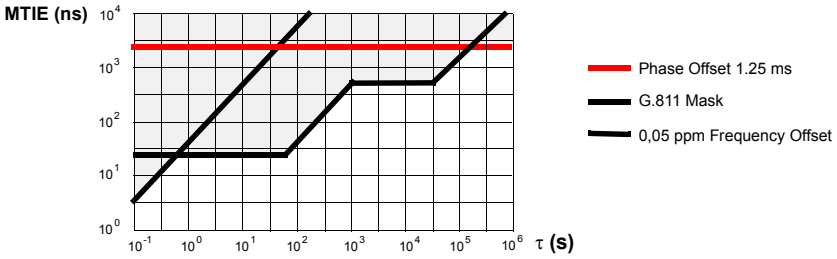

Figure 4 An MTIE mask for a Node-B synchronization source in a UMTS network

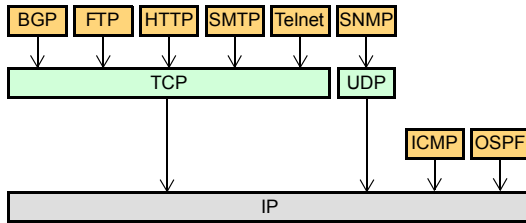

Figure 5 Higher protocols

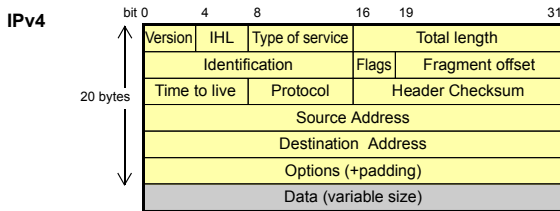

Figure 6 IP Format

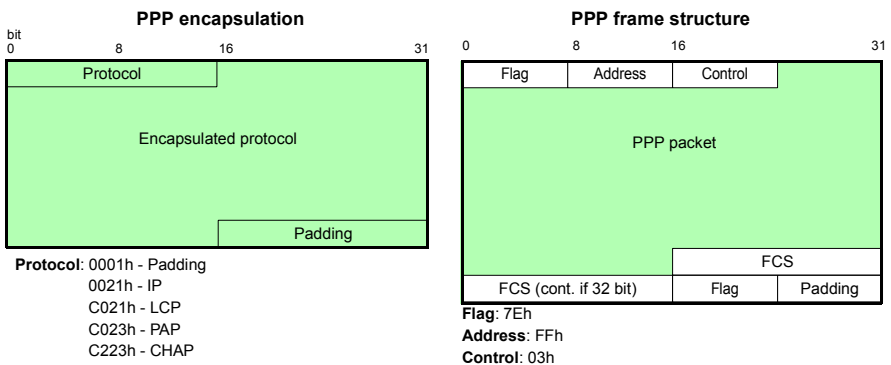
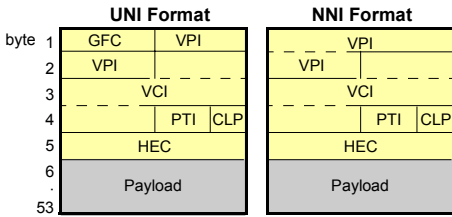

Figure 7 PPP encapsulation



Function	VPI	VCI	PTI	CLP
Unassigned	0	0	any	0
Invalid	<0	0	any	0
Idle	0	0	0	1
Metasignaling UNI	*any	1	0xx	any
Broadcast UNI	*any	2	any	any
Segment OAM F4	any	3	0xx	any
E2E OAM F4	any	4	0x0	any
P2P Signaling	*any	5	0xx	any
VP Management	any	6	110	any
ILMI	0	16	z	any
PNNI	0	18	0	any
Segment OAM F5	any	not 0, 3, 4, 6 or 7	100	any
E2E OAM F5 flow	any	not 0, 3, 4, 6 or 7	101	any
VC Resource mgt	any	not 0, 3, 4, 6 or 7	110	any
User data	any	>31	0xx	any

Figure 8 ATM Cell format

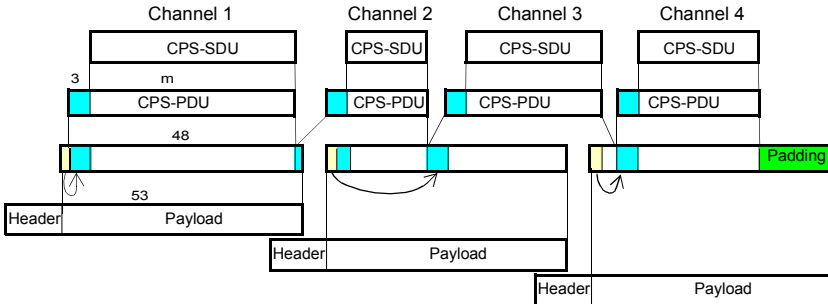

Figure 9 AAL2 format

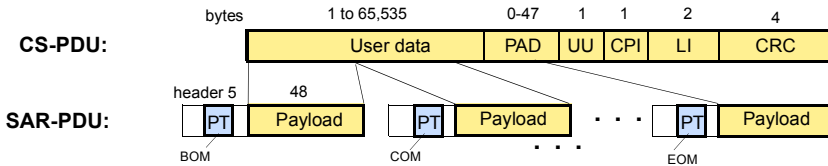

Figure 10 AAL5 format

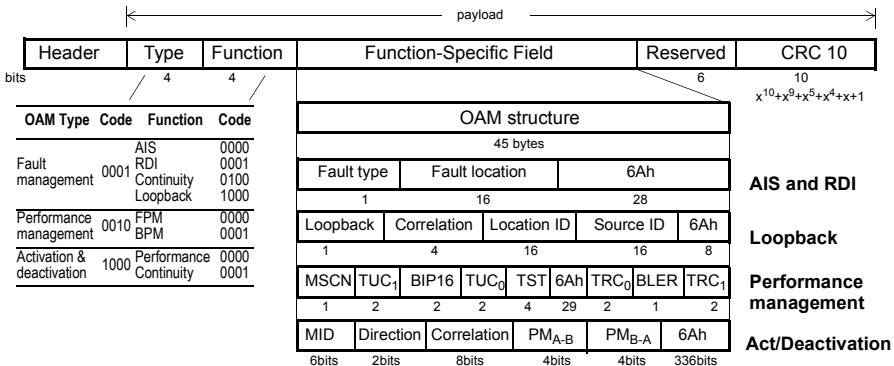

Figure 11 Format of OAM cells

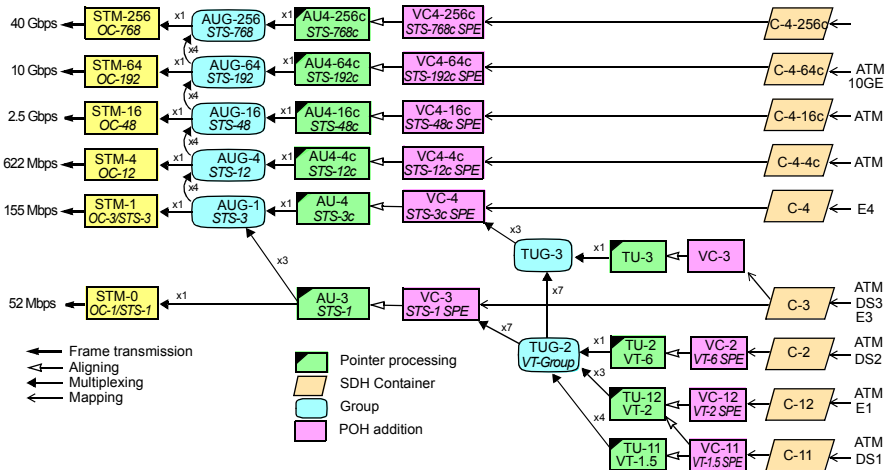

Figure 12 SDH and SONET Multiplexing map

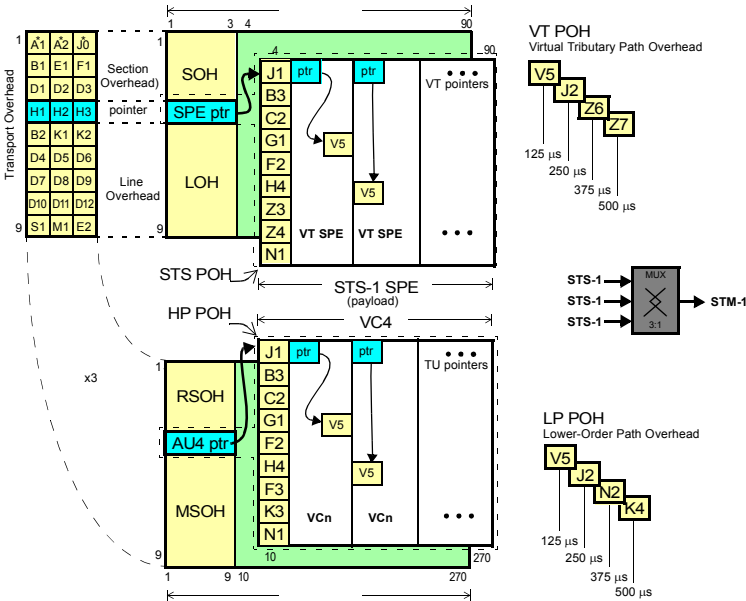

Figure 13 STS-1 and STM-1 frames

STS-1/STM-0

1	A1*	A2*	J0*
B1	E1	F1	
D1	D2	D3	
H1	H2	H3	
B2	K1	K2	
D4	D5	D6	
D7	D8	D9	
D10	D11	D12	
9	S1	M1	E2

1 STM-1/STS-3/OC-3 9

1	A1*	A1*	A1*	A2*	A2*	A2*	J0*	X*	X*
B1	^	^	^	E1	^		F1	X	X
D1	^	^	D2	^		D3			
Pointer (s)									
B2	B2	B2	K1				K2		
D4			D5				D6		
D7			D8				D9		
D10			D11				D12		
9	S1					M1	E2	X	X

J0: Section Trace
 A1= 11110110 Frame Alignment
 A2= 00101000: Frame Alignment
 B1: Section Parity Code BIP8
 B2: Multiplex Parity Code BIP-n x 24
 D1-D3: 192 kbps OA&M data
 D4-D12: 576 kbps OA&M data
 E1, E2: 64 kbps orderwire channels
 F1: 64 kbps user channel
 H1, H2, H3: pointer bytes
 K1, K2: Request /answer APS channels
 F1: 64 kbps user channel
 M0, M1: Re-sending of B2 errors
 Z0: reserved
 * Non-scrambled bytes
 X bytes reserved for national use
 ^ Media-dependent bytes

STM-4/OC-4

1	A1*	A1*	A1*	A1*	A1*	A1*	A2*	A2*	A2*	A2*	A2*	A2*	A2*	A2*	A2*	J0*	Z0*	Z0*	Z0*	X*	X*	X*	X*	X*	X*									
B1				^	^	^	E1									F1	X	X	X	X	X	X	X	X	X									
D1				^	^	^	D2									D3																		
Pointer (s)																																		
B2	B2	B2	B2	B2	B2	B2	K1																			K2								
D4							D5																				D6							
D7							D8																				D9							
D10							D11																				D12							
9	S1																										E2	X	X	X	X	X	X	X

Figure 14 STM-n/OC-m frames

Nine bytes Path Overhead (POH)

SDH	SONET	
J1	J1	Path trace, message with CRC
B3	B3	BIP-8 parity control
C2	C2	Signal label (mapping)
G1	G1	Path status
F2	F2	Path user channel (voice or data)
H4	H4	Position and sequence indicator
F3	F3	Path user channel (voice or data)
K3	Z3	Automatic Protection Switching
N1	Z4	Tandem Connection Monitoring

C2: 00: unequipped 16: HDLC/PPP 18: HDLS/LAPS
 04: E3, T3 13: ATM 1A: 10G Ethernet

G1:	REI	RDI	E-RDI	Spare
-----	-----	-----	-------	-------

REI (Remote Error Indication)
 RDI (Remote Defect Indication)
 E-RDI (Enhanced RDI information)

H4:	MFI2 (frames 0 and 1) SQ (frames 14 and 15)	Multiframe Indicator 1
-----	--	------------------------

VC-3/4-Xv sequence

K3:	APS	HODL	Spare
-----	-----	------	-------

APS: Automatic Protection
 HODL: Higher-Order Data Link

N1:	IEC	TC REI	OEI	TC-API, TC-RDI ODI, reserved
-----	-----	--------	-----	---------------------------------

IEC Incoming Error Count,
 TC-REI: TC Remote Error Indication
 OEI: Outgoing Error Indication

V5:	BIP-2	REI	RFI	Signal Label	RDI
-----	-------	-----	-----	--------------	-----

BIP-2: parity of the previous VC
 VC signal label (mapping)

K4:	ESL	VC	APS	E-RDI	DL
-----	-----	----	-----	-------	----

ESL (Extended Signal Label)
 VC (Lower Order Virtual Concatenation)
 DL: Lower Order Data Link

Four bytes Path Overhead (POH)

SDH	SONET	
V5	V5	Path Overhead
J2	J2	Path Trace
N2	Z6	Reserved or TCM
K4	Z7	Additional Path Overhead

N2: BIP-2 1 I-AIS TC REI OEI TC-API, TC-RDI
 ODI, reserved
 BIP-2 for Tandem Connection

Figure 15 Nine bytes and Four bytes Path Overhead.

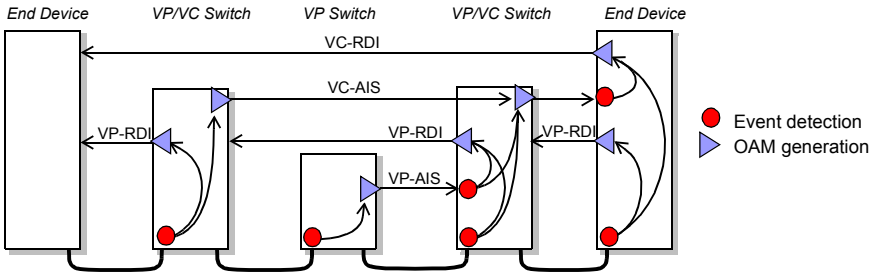

Figure 16 Generating VP-AIS/RDI and VC-AIS/RDI type OAM cells

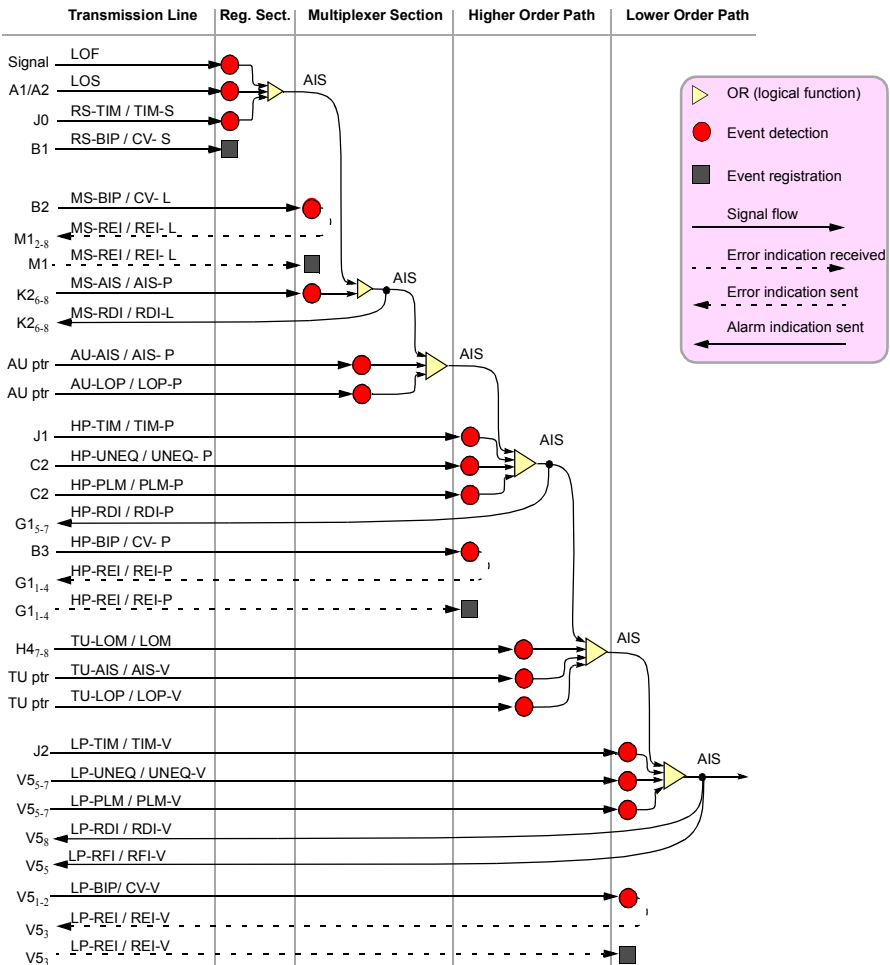

Figure 17 Events management. In Regular characters SDH, in Italic SONET.

Acronyms

AAL	ATM Adaptation Layer	NBAP	Node-B Application Part
ALCAP	Access Link Control Application Part	NMC	Network Management Centre
AMR	Adaptive Multi-Rate	OMC	Operations & Maintenance Centre
AUC	Authentication Centre	OSPF	Open Shortest Path First
CC	Country Code	PCM	Pulse Code Modulation
EIR	Equipment Identity Register	PDCP	Packet Data Convergence Protocol
FP	Frame Protocol	RANAP	Radio Access Network Application Part
GGSN	Gateway GPRS Support Node	RLC	Radio Link Control
GMSC	Gateway Mobile Switching Centre	RNC	Radio Network Controller
GPRS	General Packet Radio Service	RNS	Radio Network Subsystem
GSMS	GPRS Short Message Service	RNSAP	Radio Network Subsystem Appl Part
GTP	GPRS Tunnelling Protocol	RRC	Radio Resource Control
HLR	Home Location Register	SCCP	Signaling Connection Control Part
ICMP	Internet Control Message Protocol	SSCOIP	Service Specific Connection Oriented Protocol
IP	Internet Protocol	SGSN	Serving GPRS Support Node
Iu	UTRAN interface	SMS	Short Message Service (Generic)
M3UA	MTP3 User Adaptation Layer	SS	Supplementary Service
MAC	Medium Access Control	UMTS	Universal Mobile Telecom System
MSC	Mobile Switching Centre	UTRAN	UMTS Terrestrial Radio Access Net
MTIE	Maximum Time Interval Error	VLR	Visitor Location Register
MTP3	Message Transfer Part Level 3	WCDM	Wideband Code Division Multiple Access



More information in:

Installation and Maintenance of SDH/SONET, ATM, XDSL, and Synchronization Networks.

2003 (c) Artech House, ISBN:1580535259



Trend Communications Ltd.
Whitebrook Park,
Lower Cookham Road,
Maidenhead,
Berkshire, SL6 8XY, UK

TrendCommunications

International: +44 1628 503500

United Kingdom: 01628 503531

France: 01 69 35 54 70

Deutschland: 089 32 30 09 30

España: 93 300 3313

India: 11 25554161

Canada /Latin America: 1 256 461 0790

US Toll Free: 1 877 78TREN

Email: infoline@trendcomms.com

Web: www.trendcomms.com